

# NAPF series

型號：

① ② ③ ④ ⑤  
**NAPF** **T** **S** - **2** - **3** - **N** - **T**



① 真空接入方向

T	縱向接入
Y	橫向接入

③ 行程 mm

2.5	15
3	20
4	25
5	30
6	50
10	70

② 吸盤直徑 mm

2	∅ 2	35	∅ 35
3.5	∅ 3.5	40	∅ 40
6	∅ 6	50	∅ 50
8	∅ 8	60	∅ 60
10	∅ 10	80	∅ 80
15	∅ 15	95	∅ 95
20	∅ 20	120	∅ 120
25	∅ 25	150	∅ 150
30	∅ 30	200	∅ 200

④ 吸盤材質

N	丁腈橡膠 NBR
S	矽橡膠
NE	抗靜電丁腈橡膠
SE	抗靜電矽橡膠

⑤ 配管接頭

無標示	無接頭
T	筭型接頭
O	快速接頭

規格：

標示	材質	硬度	使用溫度範圍	顏色	膠體阻抗值
N	丁腈橡膠 NBR	A55/S	-26 °C ~ 120 °C	黑色	
S	矽橡膠	A55/S	-60 °C ~ 250 °C	乳白色	
NE	抗靜電丁腈橡膠	A70/S	-26 °C ~ 120 °C	黑色紅點	$10^5 \sim 10^7 \Omega / cm^3$
SE	抗靜電矽橡膠	A55/S	-60 °C ~ 250 °C	黑色紅點	$10^5 \sim 10^7 \Omega / cm^3$

吸盤直徑		∅ 2 ~ ∅ 8		∅ 10 ~ ∅ 15		∅ 20 ~ ∅ 50		∅ 60 ~ ∅ 95		∅ 120 ~ ∅ 200
真空接入方向		縱向	橫向	縱向	橫向	縱向	橫向	縱向	橫向	橫向
無接頭		M3	M3	M5	M5	M5	M5	Rc1/8	Rc1/8	Rc1/4
配管接頭	筭型接頭	∅ 4 x 2.5	○ (M3)	○ (M3)	X	X	X	X	X	X
		∅ 6 x 4	X	X	○ (M5)	○ (M5)	○ (M5)	○ (M5)	X	X
	快速接頭	∅ 4 x 2.5	○ (M3)	○ (M3)	X	X	X	X	X	X
		∅ 6 x 4	X	X	○ (M5)	○ (M5)	○ (M5)	○ (M5)	X	X

# NAPF series

## 外觀尺寸：

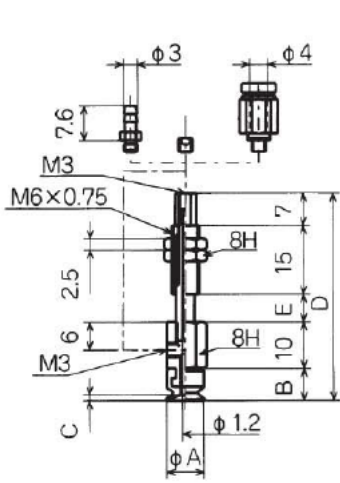

2 / 3.5 / 6 / 8

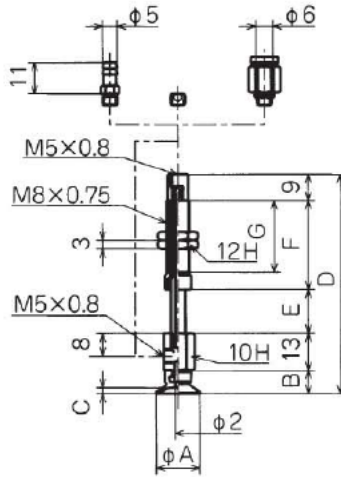

10 / 15

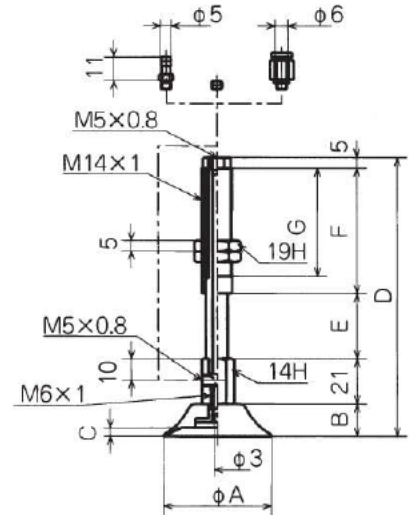

20 / 25 / 30 / 35 / 40 / 50

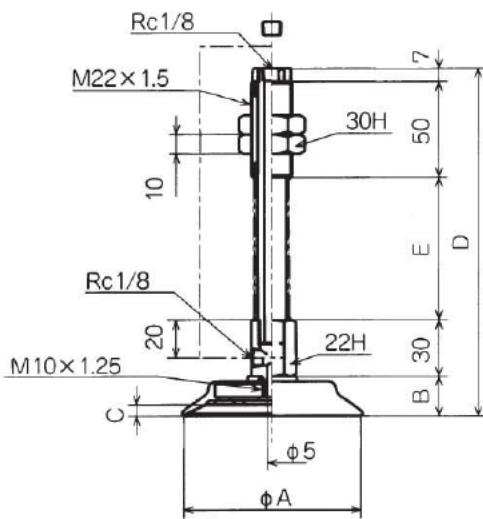

60 / 80 / 95

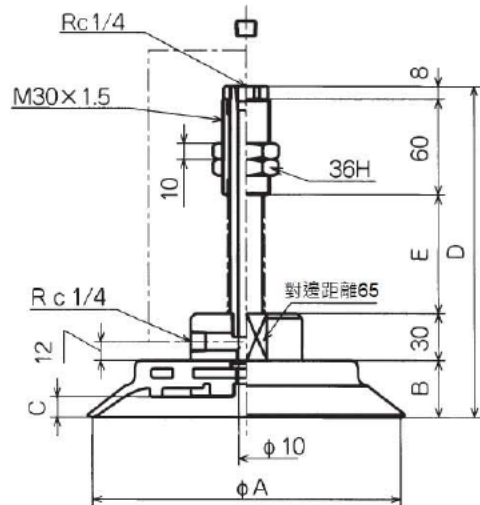

120 / 150 / 200

NAPFT / YS	A	B	C	D	E	F	G	淨重(g)
NAPFT / YS-2-3	2	4	0.5	39	3	---	---	6
NAPFT / YS-2-6	2	4	0.5	42	6	---	---	6
NAPFT / YS-3.5-3	3.5	4	0.5	39	3	---	---	6
NAPFT / YS-3.5-6	3.5	4	0.5	42	6	---	---	6
NAPFT / YS-6-3	6	6.5	0.8	41.5	3	---	---	7
NAPFT / YS-6-6	6	6.5	0.8	44.5	6	---	---	7
NAPFT / YS-8-3	8	7	1.2	42	3	---	---	7
NAPFT / YS-8-6	8	7	1.2	45	6	---	---	7

# NAPF series

## 外觀尺寸：

NAPFT / YS	A	B	C	D	E	F	G	淨重(g)
NAPFT / YS-10-3	10	7.5	1.5	55.5	3	23	17	18
NAPFT / YS-10-10	10	7.5	1.5	62.5	10	23	17	18.5
NAPFT / YS-10-15	10	7.5	1.5	75	15	30.5	24.5	21
NAPFT / YS-15-3	15	8	2	56	3	23	17	18
NAPFT / YS-15-10	15	8	2	63	10	23	17	18.5
NAPFT / YS-15-15	15	8	2	75.5	15	30.5	24.5	21
NAPFT / YS-20-6	20	12.5	2.3	80.5	6	36	28	65.5
NAPFT / YS-20-15	20	12.5	2.3	89.5	15	36	28	70.5
NAPFT / YS-20-30	20	12.5	2.3	126.5	30	58	50	95.5
NAPFT / YS-25-6	25	14	3	82	6	36	28	66
NAPFT / YS-25-10	25	14	3	91	15	36	28	71
NAPFT / YS-25-30	25	14	3	128	30	58	50	96
NAPFT / YS-30-6	30	12	2	80	6	36	28	67
NAPFT / YS-30-15	30	12	2	89	15	36	28	72
NAPFT / YS-30-30	30	12	2	126	30	58	50	97
NAPFT / YS-35-6	35	14	3	82	6	36	28	69.5
NAPFT / YS-35-15	35	14	3	91	15	36	28	74.5
NAPFT / YS-35-30	35	14	3	128	30	58	50	99.5
NAPFT / YS-40-6	40	14	3.5	82	6	36	28	71
NAPFT / YS-40-15	40	14	3.5	91	15	36	28	76
NAPFT / YS-40-30	40	14	3.5	128	30	58	50	101
NAPFT / YS-50-6	50	15	4	83	6	36	28	80
NAPFT / YS-50-15	50	15	4	92	15	36	28	85
NAPFT / YS-50-30	50	15	4	129	30	58	50	110
NAPFT / YS-60-10	60	18.5	5	125.5	20	---	---	282.5
NAPFT / YS-60-30	60	18.5	5	155.5	50	---	---	316.5
NAPFT / YS-60-50	60	18.5	5	180.5	75	---	---	343.5
NAPFT / YS-80-10	80	20.5	6	127.5	20	---	---	310.5
NAPFT / YS-80-30	80	20.5	6	157.5	50	---	---	344.5
NAPFT / YS-80-50	80	20.5	6	182.5	75	---	---	371.5
NAPFT / YS-95-10	95	21	6	128	20	---	---	350.5
NAPFT / YS-95-30	95	21	6	158	50	---	---	384.5
NAPFT / YS-95-50	95	21	6	182	75	---	---	411.5
NAPFT / YS-120-20	120	24	6	157	35	---	---	1165
NAPFT / YS-120-50	120	24	6	197	75	---	---	1246
NAPFT / YS-150-20	150	31	9	164	35	---	---	1389
NAPFT / YS-150-50	150	31	9	204	75	---	---	1470
NAPFT / YS-200-20	200	36	13	169	35	---	---	1755
NAPFT / YS-200-50	200	36	13	209	75	---	---	1836